

# Manual y Especificaciones Técnicas

## Technical Specification and Manual

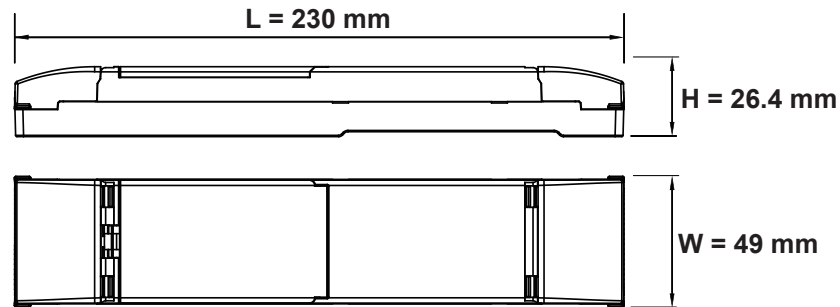
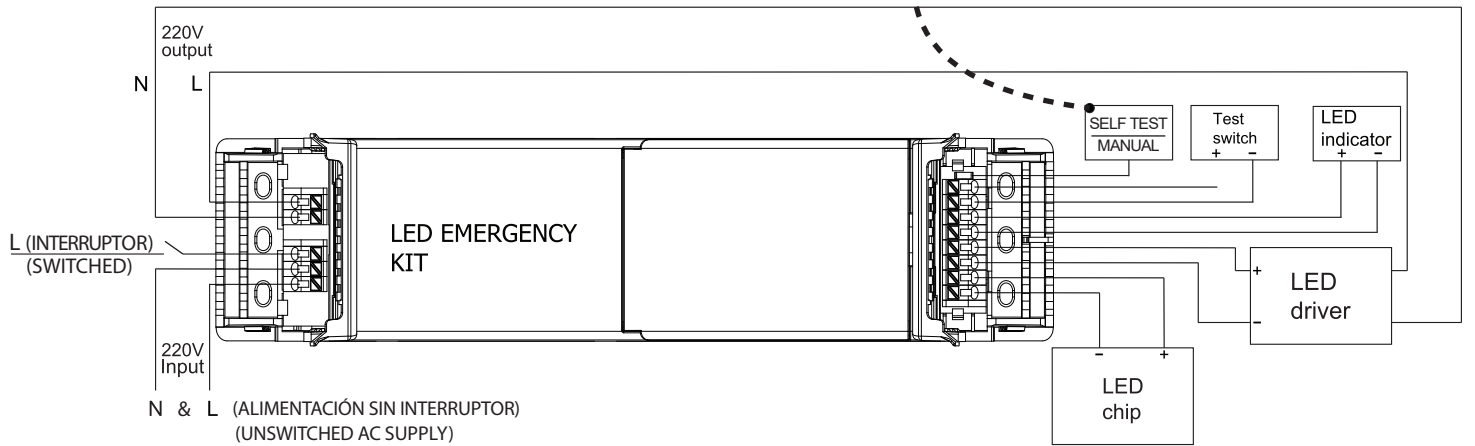
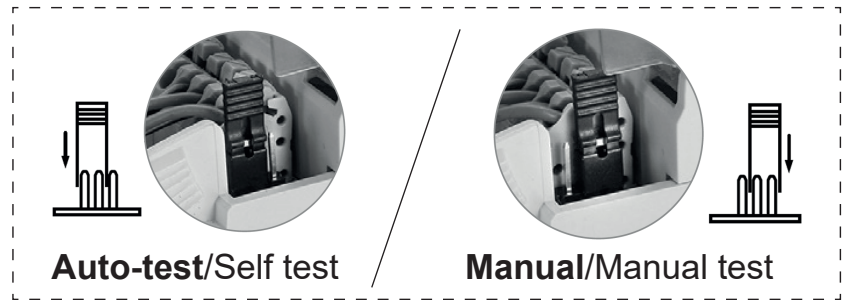

### Características:

#### Technical Details:

<b>Alimentación/Mains Supply</b>	220-240VAC 0.03A 50/60 Hz
<b>Potencia/Power</b>	3W
<b>Duración/Duration</b>	3h
<b>Tiempo de Recarga/Recharge Period</b>	24h
<b>Batería/Battery</b>	6.4V 1800mAh
<b>Intensidad de Carga/Charge Current</b>	180mA
<b>Desconexión Batería (V)/Battery Cut-Off Voltage</b>	5V

<b>Ta y Tc Max/Max Ta and Tc</b>	Ta: 45 °C Tc: 70 °C
<b>Temperatura Batería Max/Max Battery Temperature</b>	60 °C
<b>Intensidad de Descarga/Battery Discharge Current</b>	450mA
<b>Voltaje Max Descarga/Discharge Voltage Limit</b>	5.5V
<b>Indice de Protección/Ingress Protection</b>	IP20
<b>Sección Cable Admitido/Terminal Screw &amp; Push</b>	0.75 mm <sup>2</sup> -1.5 mm <sup>2</sup>
<b>Dimensiones (LxWxH)/Module Dimensions</b>	230x49x26.4mm

